



Chiller/Freezer Cabinet

MBC24G/MBC24FG



Chiller/Freezer Cabinet

MBC24R/MBC24F

FEATURES

- Gross capacity 105 litres
- Net usable capacity 50 litres
- Holds up to 8 milk bottles
- Maximum ambient temperature of 43C
- Climate class 5
- Energy classification A+
- Digital temperature display
- 2 shelves W380 x D475mm and base
- Ventilation, fan cooled
- C5H10 insulation
- Magnetic door gaskets
- Self closing and stay open door
- Internal LED lighting
- Lockable door as standard
- High grade 304 stainless steel interior
- High grade 304 Stainless steel exterior
- Heavy duty Embraco compressors
R600a GAS (Fridge) and R290 GAS (Freezer)
- Gross weight 67kg, nett weight 62kg



CHILLER/FREEZER CABINET

MBC24FG/MBC24G

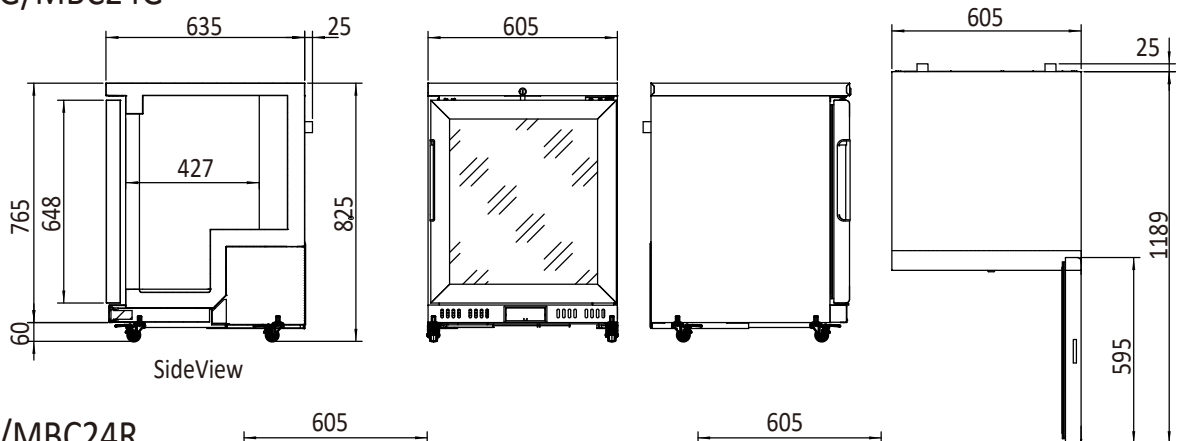

MBC24F/MBC24R

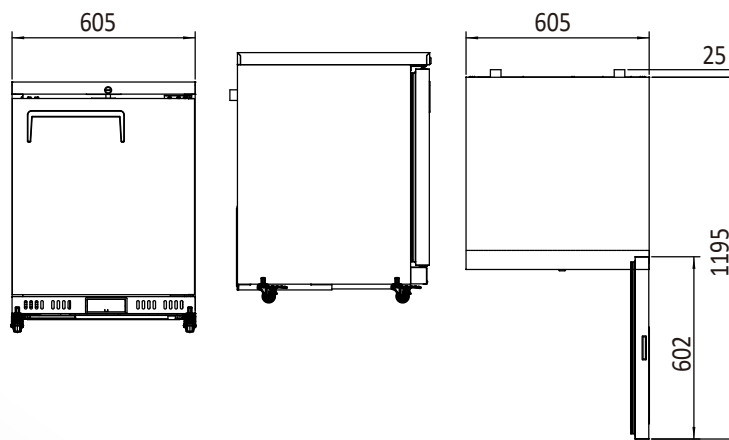

INFORMATION	MBC24G	MBC24FG	MBC24R	MBC24F
Capacity	105L	105L	105L	105L
Power	150W/10A	500W/10A	150W/10A	300W/10A
Voltage	220~240V/50Hz	220~240V/50Hz	220~240V/50Hz	220~240V/50Hz
Working Temp	0 ~ +8°C	-20 ~ -17°C	0 ~ +8°C	-22 ~ -17°C
Ambient Temp	43°C	43°C	43°C	43°C
Dimensions(mm)	W605 x D635 x H785,53kg	W605 x D635 x H785,57kg	W605 x D635 x H785,48kg	W605 x D635 x H785,52kg
Packaging Dimensions(mm)	W655 x D700 x H940,63kg	W655 x D700 x H940,68kg	W655 x D700 x H940,58kg	W655 x D700 x H940,62kg



2 YEARS WARRANTY ON ALL PARTS AND LABOUR
EXTRA 2 YEARS WARRANTY ON PARTS
WHEN YOU REGISTER WITH US ONLINE



* All prices are EX-GST